

# JANUS FIRE PUMPS

PUMPS AXIAL  
PISTON





# WaterQuest Solutions

## JANUS FIRE PUMPS AXIAL PISTON

Our Janus axial piston pumps are totally oil free, clean and completely safe to use. As a result of employing advanced materials, high velocity and loaded sliding surfaces, the range of pumps can operate effectively with water as their only coolant/lubricant therefore, this removes the potential for cross contamination of the system fluid or lubricating oil.

Each pump employs technology which minimises vibration and ensures a low noise yet high efficiency operation; the result is an exceptionally small, light-weight product.

ATEX approved to comply with regulations of Directive 94/9/EC for equipment or protection systems intended for use in potentially explosive atmospheres.

Product group, category, zones: II 2GD ck T6 T85°C +1°C≤TA≤+40°C.

Manufactured mainly in 316 stainless steel as standard, the product offers excellent resistance to corrosive fluids. The materials utilised internally can be selected to suit the most appropriate combinations for not just tap water but also sea water and various other fluids.

Minimal pulsation is experienced with these units due to the multiple piston design and the high operational speeds. Accurate flow metering is simply achieved with the control of the output shaft speed.

The target market for the Janus fire pumps is high pressure water mist via suppression systems.

Developed for exceptional life and long term short duty functions, with five year service intervals. Also no inlet check valves are required which could prevent pump from operation.

Can be used as a jokey pump and for firefighting with the use only of an inventor drive

The Janus fire pump is the most compact, lightweight pump available on the market with a mechanical efficiency in excess of 90%

SPECIFICATION		
Pumps		P10
Displacement (cc/rev)		10.5
Max. RPM		3000
Max. Input Power (kW)		5.5
Max. Water Flow (l/min)		31.5
Max. Cont. Pressure (Bar)		100
Weight (kg)		2
Temperature (°C)	Max: **	50
	Min: ***	2

\*\* Higher temperature operation is possible, consult TWHC for details. \*\*\* Consult TWHC for antifreeze option and lower temperature conditions.

# JANUS FIRE PUMPS

## AXIAL PISTON

### Motor Pump Assemblies

A standard range of bell housings and couplings are available for connecting the pumps to the B5 electric motor flange. The pumps are not capable of operating with induced axial or radial loads on the output shaft; always adopt the use of a 3 part gear style coupling where possible. If the drive shaft/spigot location is within 0.05mm concentricity, direct inline drive assemblies are permissible.

### Temperature

The units will generate full performance from 2°C to 50°C. For temperatures below freezing, an environmentally friendly antifreeze is available; ask for the Monopropylene Glycol datasheet. Operation above 50°C is possible however, the volumetric efficiency of the unit will be affected. Consult TWHC and specify the maximum operating temperature.

### Filters

All incoming water to the pumps must be pre-filtered to a nominal rating of 10µm (25µm absolute) with a filter element rating of  $\beta_{10} = 75$  or better. Return line filtration is advisable on closed loop systems. High pressure filtration may also be considered but as these are manufactured in stainless steel, we consider this an expensive option.

### Fluid

Drinking water quality conforming to the EEC-directive 98/83/EC should be used as standard. Consult TWHC if you are unsure of the water quality. The standard product will operate happily on technical water i.e. distilled, RO water or demineralised. Changes may need to be made to the seal material or construction depending on the operating environment. The pumps also operate on non-flammable fluids such as Glycol 95/5 mixtures; internal clearances must be adjusted when functioning on such fluids. It is imperative the exact operating fluid is specified on all enquiries and orders. The standard construction will operate on sea water however, due to the increased corrosion potential of the fluid, a more noble material construction may be required for long term operation.

## INLET CONDITIONS

### 2 Port Design

Predominantly used in power pack applications where the supply water is fed to the pump from a low pressure source i.e. local tank or water mains with very low supply pressure. This design of pump can not lift water and the inlet pressure must be positive at all times. The pipe-work must be sized to ensure that even under minimum head conditions, the water pressure is still positive at the inlet. Failure to ensure this can result in premature pump failure. A simple check is to remove the pump inlet hose and measure the flow. The inlet flow rate must be 20% over the maximum delivery flow when the tank is at it's lowest level. This ensures the inlet has positive pressures under dynamic conditions.

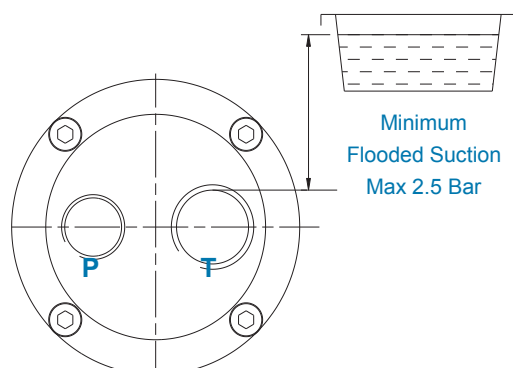

### Unboosted

Do not place a filter between the tank and pump unless a pressure switch protecting against negative pressure is fitted. Filter all water upon entry to the tank. All supply pipe work to be a maximum diameter and minimum length.

The ports are clearly marked P (pressure) and T (tank) do not reverse or turn the shaft in the wrong direction or failure will result.





WaterQuest  
Solutions

# JANUS FIRE PUMPS

P10 PUMP DIMENSIONS

P10

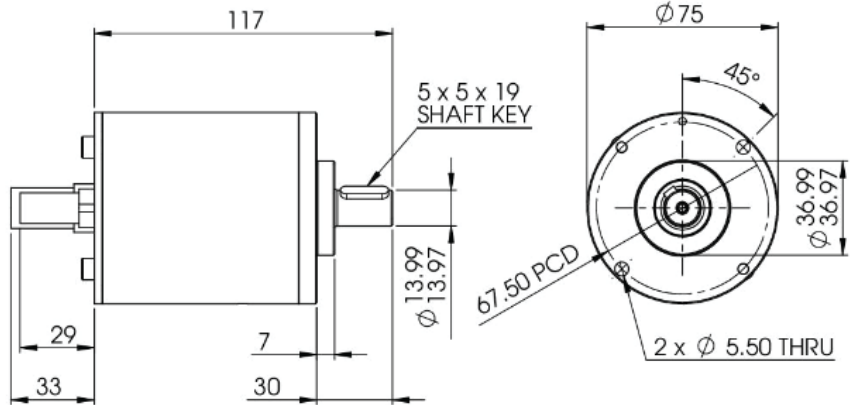
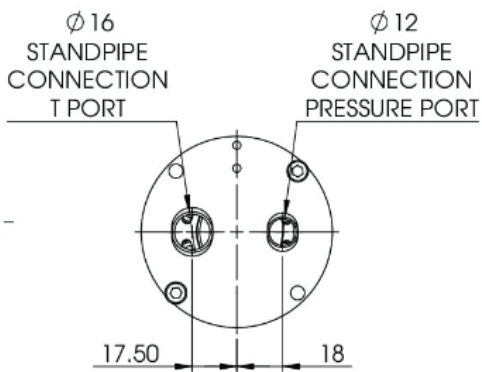
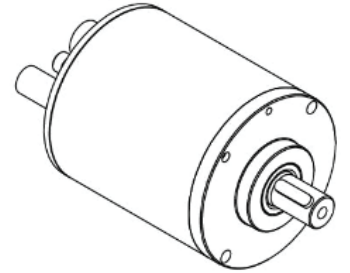

# JANUS FIRE PUMPS

## P10 PUMP PERFORMANCE DATA

### Output Flow

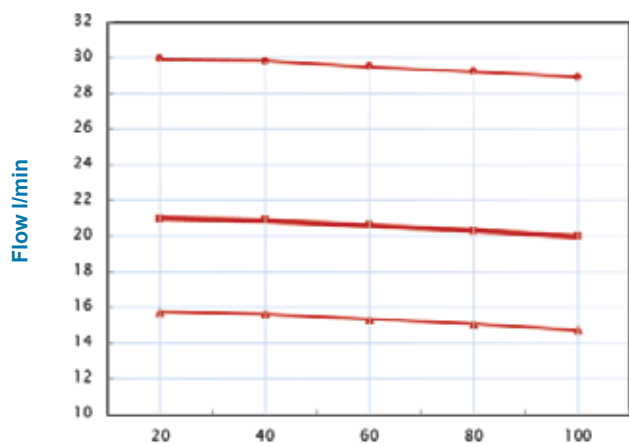

Pressure (bar)

— 10.5cc 2850rpm — 10.5cc 2000rpm — 10.5cc 1500rpm

### Input Power kW

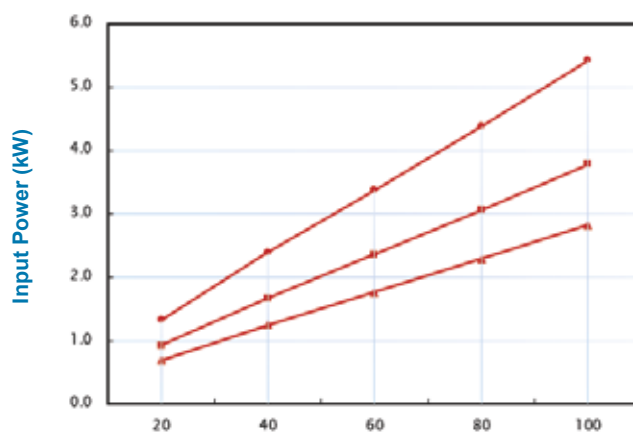

Pressure (bar)

— 10.5cc 2850rpm — 10.5cc 2000rpm — 10.5cc 1500rpm

### Input Torque

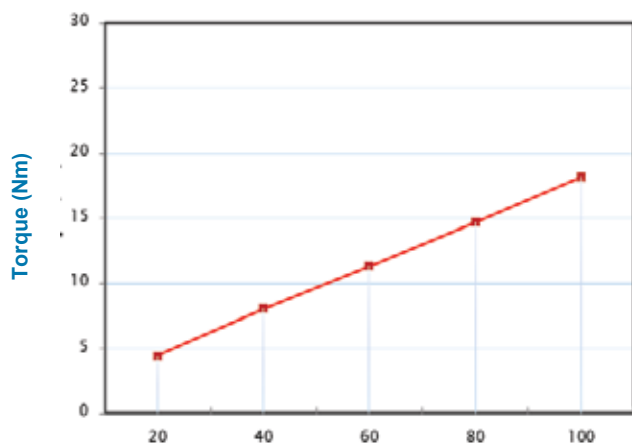

Pressure (bar)

— 10.5cc 2850rpm

### Overall Efficiency

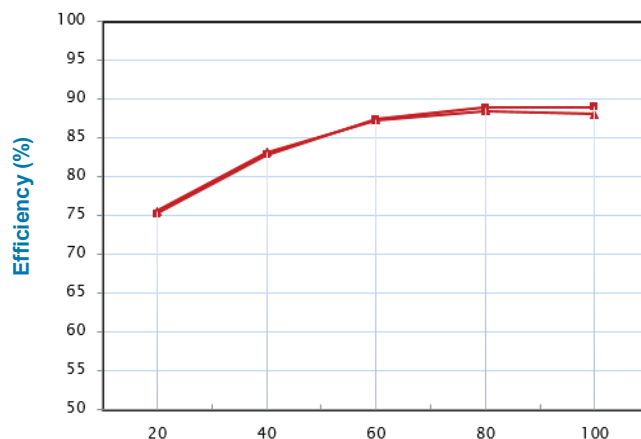

Pressure (bar)

— 10.5cc 2000rpm — 10.5cc 2850rpm